

Installing a floor

The wood is dried to approximately 8% moisture. This insures minimal floor movement. It is important to remember that wood is an organic material, and it shrinks and expands over time. This amount of shrinkage and expansion is dependent on the humidity and temperature of the room. 30-60% humidity is ideal for solid wood floors.

We recommend that the planks be screwed tight or nailed down so that each plank moves individually. Sekelgolvet Floors can also be glued floating if there is no surface for screws or nails (but not the 14 mm planks in rooms wider than 3.5 m). You can also install a Baseco floor over floor heating.

It's easy to install Sekelgolvet Floors, but you'll need some basic joinery skills. Instructions are always included with the flooring. If you prefer, contact a professional to install the floor.

Assembly instructions

Sekelgolvet floors should be stored in their sealed packaging until they are to be installed. Use a moisture seal if even the slightest risk of moisture under the flooring exists and always when installing onto concrete.

Make sure the underlying surface is level and lay rag board or equivalent material on joist surfaces next to the wood floor. The end-seams may be placed between the joists when laying 25 mm flooring on joists c/c 600 mm. Glued floating flooring should never be combined with flooring that is screwed or nailed into place.

It is recommended that if floor heating is also installed, the wood floor be installed using screws or nails. Avoid using the heating the first three weeks after the floor is installed. Sekelgolvet floors on floor heating may result in larger shrinkage slots than without floor heating. Sekelgolvet floors may be heated to a maximum of 28° C.



Screwing or nailing

Special screws are available for all sizes of Sekelgolv floors that prevent cracking when placing screws along edges of dry wood. Baseco screws: PTS 28 for 14 mm floors, PTS 48 for 20 mm floors, PWS 47 for 25 mm floors and PWS 62 for 30 mm floors.

Galvanised wood nails are recommended for nailing. For tight end seams (not long ends!), short ends should be glued. When varnishing Sekelgolv floors installed with screws or nails, there is the risk of varnishing the floor boards together, which can result in occasional large and uneven slots between boards.

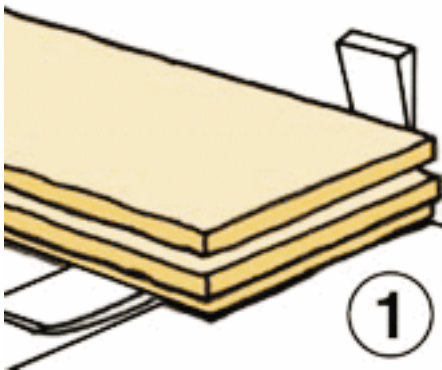

Adjust the first board so it is straight and use wedges or distance pieces to leave a 5-10 mm gap between the wall and the board.

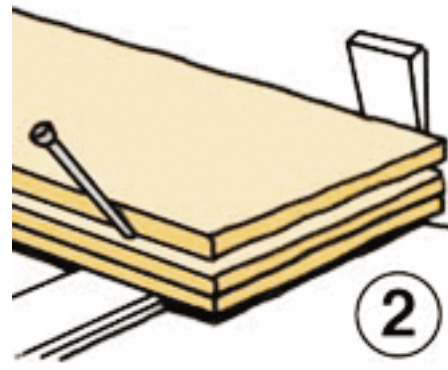

Screw/nail diagonally into the top side of the board's tongue. Our screws are self-recessing. Nails are recessed using a mandrel.

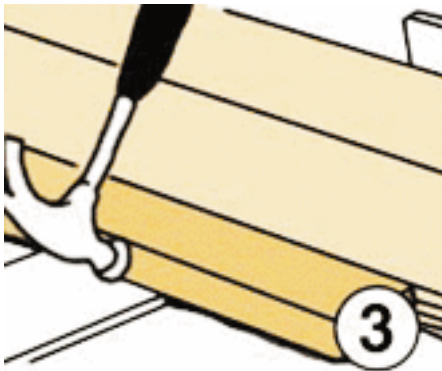

Hammer in the next board using a wide block and a heavy mallet. Install as shown in picture 2..

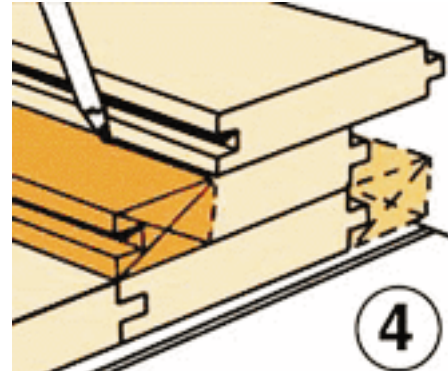

This is how you adjust the last board.

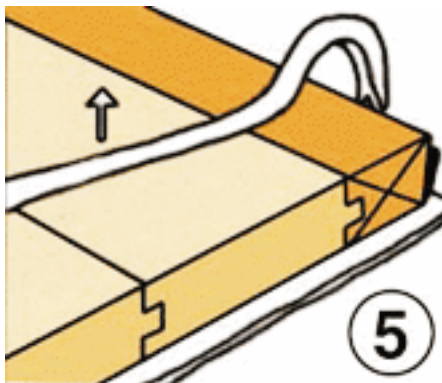

You can put the last board in place using a crowbar.



Gluing

Never place heavy objects, such as kitchen furnishings or walls on a glued floor that could prevent the floor from expanding and contracting. When gluing floors in larger rooms, angled floors, or combinations with several rooms, the floor should be divided with free-moving joints.

14x113 mm Sekelgolv flooring should not be glued in rooms wider than 3.5 metres.

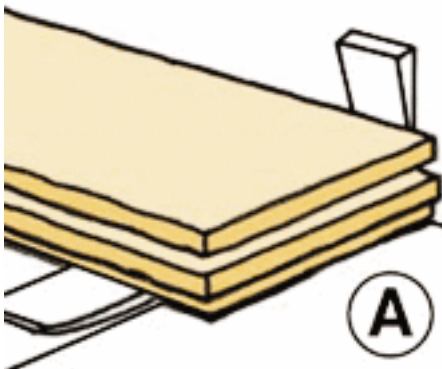

Make sure you install the first board straight and leave 10 mm space between the board and the wall using wedges or distance pieces.

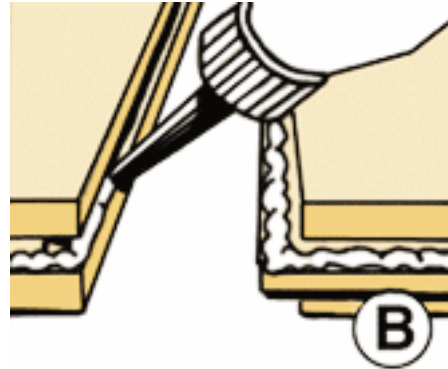

Lay a line of glue on the top of the board's tongue and a small line of glue on the lower part of the mating board's groove.

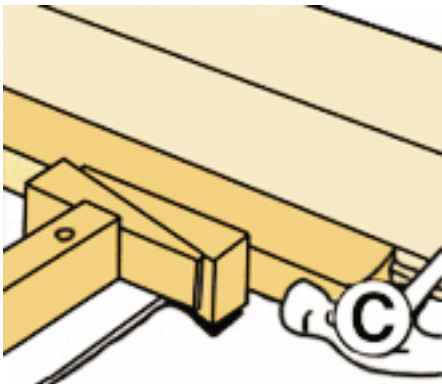

Hammer in the next board with a wide block to avoid damage to the board. Pull tightly together and place wedges so the joints are completely tight. Wait until the glue has dried, normally 7-10 minutes. Excess glue is wiped away with a moist rag.

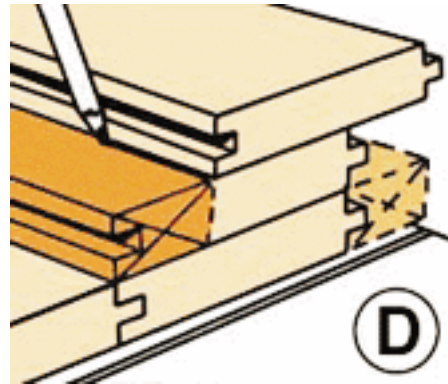

This is how you adjust the last board.

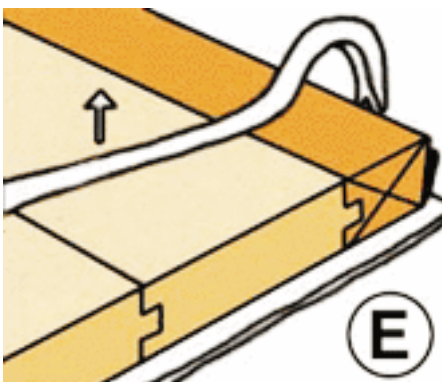

Press the board into place using a crowbar.